

TRANSFORMER OIL FILTERING, DEGASATION AND DRYING UNIT MODEL S 2000 VARIO



Kondić



S-50



S-250



S-500



S-500



S-1000



S-1000



S-2000



S-3000 Vario



S-4000



S-4000



S-4000 Vario



S-3000 / 6000

LIST OF REFERENCES

SOLD UNITS:

1. State Railway Company - Beograd (Serbia and Montenegro)
2. Electrodistribution – Subotica (Serbia and Montenegro)
3. Thessalonica (Greece)
4. Baghdad (Iraq)
5. Electrodistribution – Mostar (Bosnia and Herzegovina)
6. Electrodistribution – Banja Luka (Bosnia and Herzegovina)
7. Mašinoinženjering – Beograd (Serbia and Montenegro)
8. Electrodistribution – Knin (Croatia)
9. Petar Drapšin-Mladenovac (specific impregnation Unit)
10. Electrodistribution –Knin (Croatia) – Unit for drying of transformer coils
11. Yugoslav crude oil pipeline - Zagreb (Croatia)
12. Šinvoz – Zrenjanin (Serbia and Montenegro)
13. Electrodistribution – Slovengradec (Slovenia)
14. Electrodistribution – Vranje (Serbia and Montenegro)
15. Electrodistribution – Prijedor (Bosnia and Herzegovina)
16. Electrodistribution – Užice (Serbia and Montenegro)
17. Electrodistribution – Požarevac (Serbia and Montenegro)
18. Electrodistribution – Sarajevo (Bosnia and Herzegovina)
19. SANU - specific Unit
20. Skopski leguri – Skopje (Macedonia)
21. Faculty of Technology and Metallurgy – Unit for transformer oil regeneration
22. Elektroremont -Banovići (Bosnia and Herzegovina)
23. Elektroprijenos – Banja Luka
24. Energoprojekt – Nigeria (S 4000)
25. Elmar International - Beograd
26. Economic – Vitez (Bosnia and Herzegovina)
27. Natron Hyat – Maglaj (Bosnia and Herzegovina)
28. MST LLC – Baku (Azerbaijan)
29. RMU Đurđevik – Đurđevik (Bosnia and Herzegovina)
30. Blutel - Banja Luka (Bosnia and Herzegovina)
31. Electrical Engineering Institute Nikola Tesla–Belgrade (S 3000 Vario)
32. Electrodistribution – Serbia (S 2000)
33. Electrical Engineering Institute Nikola Tesla–Belgrade (Mobile unit for decontamination of PCB contaminated equipment)

34. Energoprojekt – Nigeria (S 1000)
35. Energoprojekt – (S 600)
36. Ultra Komerc – Serbia (S 1000)
37. EGU – HV Laboratory a.s. – Czech Republic (S 4000 Vario)
38. SIEMENS AG OESTERREICH – Austria (S 250)
39. KONDICH RUS – Russia (S 1000)
40. ENERGIOMONTAŽA – Serbia (S 500)
41. FLUKS – Serbia (S 500)
42. HYDEX TRIPLE R – France (S 500)

PROVIDED SERVICES - FILTERING, DRYING AND DEGASSING OF TRANSFORMER OIL:

1. HYDROPOWER PLANTS “Vlasinske”: VRLA 1,2,3,4
2. Stadium "FC Partizan" – Belgrade
3. Stadium "FC Red Star" – Belgrade
4. TRAYAL – Kruševac
5. JAT – Beograd
6. TIGAR - Pirot
7. Elektrovod - Beograd
8. FAM -Kruševac
9. Electrodistribution - Kragujevac
10. Electrodistribution - Beograd
11. Electrodistribution – Novi Sad
12. Kluz - Beograd
13. Electrodistribution - Pančevo
14. ŽUPA - Kruševac
15. Prva Iskra – Barič
16. Rekord – Beograd
17. 14. Septembar, Elektromont – Užice
18. American embassy – Beograd
19. TEP – Zagreb
20. Zorka-zaštita bilja – Šabac
21. ŽTP - Makiš
22. Coca - Cola – Beograd
23. ZMAJ – Zemun
24. State Government
25. Mostogradnja – Beograd
26. State parliament

27. Hipol - Odžaci (hidraulično ulje)
28. National security – Bgd
29. GSP – Beograd
30. Minel ELIP
31. Elektroprivreda – Beograd
32. Vrenje – Beograd
33. Minel Dinamo – Beograd
34. DUGA – Beograd
35. IMT - Beograd
36. Zavod za mere i dragocenosti
37. Galenika – Beograd
38. Tipoplastika - G.Milanovac
39. Elektrodistribucija - Banja Luka
40. BIP - Sladara – Čačak
41. Elektromontaža – Beograd
42. Pekara "KLAS" - Beograd
43. Sartid 1913 (beli limovi) – Šabac
44. "POLITIKA" AD - Beograd
45. GP " Ratko Mitrović " – Beograd
46. Institut "VINČA" – Beograd
47. Stari arhiv Jugoslavije – Beograd
48. "KNJAZ MILOŠ" – Arandelovac
49. Napredak – Ratkovo
50. "JUGOPETROL" – Smederevo
51. Beogradski sajam – Beograd
52. PC Ušće - CK Beograd
53. "Politika" - pogon Krnjača
54. Sugar factory – Crvenka
55. Rafinerija – Beograd
56. Vazduhoplovni zavod " Moma Stanojlovic" – Batajnica
57. Tehnoauto – Požarevac
58. Minel ELVO - N.Beograd
59. CER – Čačak
60. Filip Kljajić – Kragujevac
61. Naftna polja – Tenje
62. MKS – Smederevo
63. SFS - Paraćin
64. BIP – Beograd
65. Elind Teur – Valjevo
66. Rafinery – Belgrade
67. Hotel " SLAVIJA"

68. "IPOK" – Zrenjanin
69. "SUNOKO" – Sugar factory Pećinci (turbine oil)
70. "SUNOKO" – Sugar factory Bač (turbine oil)
71. Vojvodinaput – Zrenjanin
72. „ANODA“ - Valjevo
73. „TIZ“ – Zemun
74. „NAPREDAK“ – Stara Pazova
75. "INSTITUT ZA KUKURUZ" – Zemun Polje
76. " IHIS - IRITEL" - Zemun
77. "METALAC" – Gornji Milanovac
78. "MSK" – Kikinda
79. Ihis materijali – Beograd
80. Victoria group – Šid
81. Industrija brusnih alata – Ada
82. Jugoistok Niš –Tešica unit
83. Beogradske elektrane (Toplana Novi Beograd)
84. ELECTRODISTRIBUTION – ED Beograd, permanent contract on filtering of oil and pumping into high-voltage 110 kV underground cable
85. TITAN Cement Factory – Kosjerić
86. MERCEDES - Beograd
87. SIRMIUM STEEL – Sremska Mitrovica
88. Vulkan – fabrika gume - Niš
89. VMC – Beograd
90. BN BOSS – Beograd
91. THERMOELECTRIC PLANT Veliki Crljeni - Kolubara
92. Lepenka – Novi Knezevac
93. THERMOELECTRIC PLANT Morava - Svilajnac
94. JRB – Pančevo
95. Elektromreža Srbije - Srbobran
96. Elektromreža Srbije - Kruševac
97. Elektromreža Srbije - Bor
98. THERMOELECTRIC PLANT - Sremska Mitrovica
99. THERMOELECTRIC PLANT - Zrenjanin
100. Senjski rudnik - Čuprija
101. Electrodistribution - Bor
102. Electrodistribution Bor - Žugubica
103. Electrodistribution Bor – Selište Zlot
104. Electrodistribution Lazarevac
105. Electrodistribution Valjevo (Mionica)
106. Electrodistribution Užice - Požega

- 107. Electrodistribution Čačak (Ivanjica)**
- 108. Electrodistribution Užice - Bajina Bašta**
- 109. HYDROPOWER PLANT Bajina Bašta – Đurići**
- 110. Electrodistribution Loznica - TS Loznica 4**
- 111. Electrodistribution Subotica**
- 112. THERMOELECTRIC PLANT Kolubara A, Blok 2**
- 113. PK Kolubara -Suva separacija**
- 114. PK Kolubara - TS Nova Toplana**

TECHNICAL CHARACTERISTICS OF THE UNITS PRODUCED BY „KONDIC DOO“

Unit type	S500	S1000	S2000	S3000	S4000	S6000	S9000
Maximal oil flow (l/h)	500	1000	2000	3000	4000	6000	9000
Adjustable oil flow (l/h)	150-500	300-1000	600-2000	900-3000	1200-4000	1800-6000	2700-9000
Heating power (kW) (No. of stages)	7 (1x7)	15 (2x7.5)	30 (2x15)	45 (3x22.5)	60 (2x30)	90 (3x30)	135 (3x45)
Vacuum pump capacity (m ³ /h)	16	25	63	63	100	2x160	2x250
Fine filter (μm)	1-3	1-3	1-3	1-3	1-3	1-3	1-3
Inlet moisture content (ppm)	50	50	50	50	50	50	50
Outlet moisture content (ppm)	2 – 5	2 – 5	2 – 5	2 – 5	2 – 5	2 – 5	2 – 5
Inlet gas content (%vol.)	10	10	10	10	10	10	10
Outlet gas content (%vol.)	0.05	0.05	0.05	0.05	0.05	0.05	0.05
Min. Inlet temperature (t °C)	5	5	5	5	5	5	5
Differential temperature (inlet/outlet) (Δt °C)	28	28	28	28	28	28	28
Dimensions of the Unit (mm) (L/W/H)	1200 500 1600	1700 900 1750	1900 1100 1700	2000 1200 2000	2000 1200 2000	2500 1800 2300	3500 2200 2500
Weight of the Unit (kg)	350	450	550	700	800	1500	3000

Unit can be produced in accordance with specific requests of the Client (additional vacuum pump, additional heater, etc.)

Temperature load of the heaters is 1 W/cm².

TRANSFORMER OIL FILTERING, DEGASSING AND DRYING UNIT

MODEL S2000 Vario

SPECIFICATION

Adjustable oil flow rate	from 600 - 2000 l/h
Maximal oil flow rate	2000 l/h
Heating capacity	30 kW (2 x 15 kW)
Adjustable oil temperature range	0 °C – 90 °C
Differential temperature (inlet/outlet)	approx. 28 °C
Minimal oil inlet temperature	5 °C
Vacuum pump capacity	63 m ³ /h
Filter fineness	3 microns
Total power	32 kW
Final oil qualities, after three passes:	
- water content	2 - 5 ppm
- gas content	0.05 % Vol
Operating pressure in degassing tank	2 - 9 mbar
Unit, size (L x W x H)	1900x1100x1700 mm
Unit, weight	approx. 500 kg

Above mentioned values after conditioning are guaranteed when treating naphthenic based mineral oils with normal foaming conditions

The Unit is delivered ready for operation, together with:

- control panel, wiring, two connecting hoses for oil (each 10 m long) and safety devices which provides maximum operating security;
- frequency converter for adjustment of flow rate from 30% to 100% of the capacity of the gear pump and digital flow meter
- specially designed system in the degassing tank which provides uniform distribution of the processed oil in the low-pressure environment, in order to achieve best treatment results;
- trailer for road transportation of the Unit;
- spare filter cartridge with 3 micron fineness;
- spare heating element.

BRIEFLY ABOUT THE UNIT

The Unit **S2000 Vario** is designed for filtering, drying and degassing of transformer oil.

The model and the example that were kept in mind during development and construction of this Unit were the machines, which proved to be most efficient in operation, built by leading European manufacturers.

All essential parts of the Unit (vacuum pump, gear pump, electromagnetic valve and floater) are produced by leading German manufacturers. Some of the components (such as fine and coarse filters, temperature control, construction of the heaters, gear pump) had to be modified to improve the operation of the Unit and to eliminate shortcomings noticed in the operation of some other machines of this kind.

BRIEFLY ABOUT THE PROCESS

The electrical properties of insulating oil (such as puncture voltage and coefficient of losses) can be considerably improved by its filtering, degassing and dehydration. Only properly and sufficiently filtered and dried oil is suitable for filling up of the transformer. Even brand-new oil is rarely clean enough to be used in high-voltage installations, as it is often already polluted in the transporting barrels and it may absorb too much moisture in contact with air. During its operation, transformer-insulating oil is absorbing moisture over its free surface in the expansion vessel and it becomes polluted by absorbing dirty particles, fibers, soot and aging products. Therefore, oil conditioning has to eliminate the following:

- solid particles
- free and dissolved water
- dissolved gasses

The puncture voltage can be considerably increased and the coefficient of losses $\tan\delta$ improved by filtering, degassing and dehydration of insulating oil to the extent depending on moisture content. The following graph shows insulating oil characteristics in relation to moisture content:

OIL DIELECTRIC STRENGTH VS. MOISTURE CONTENT

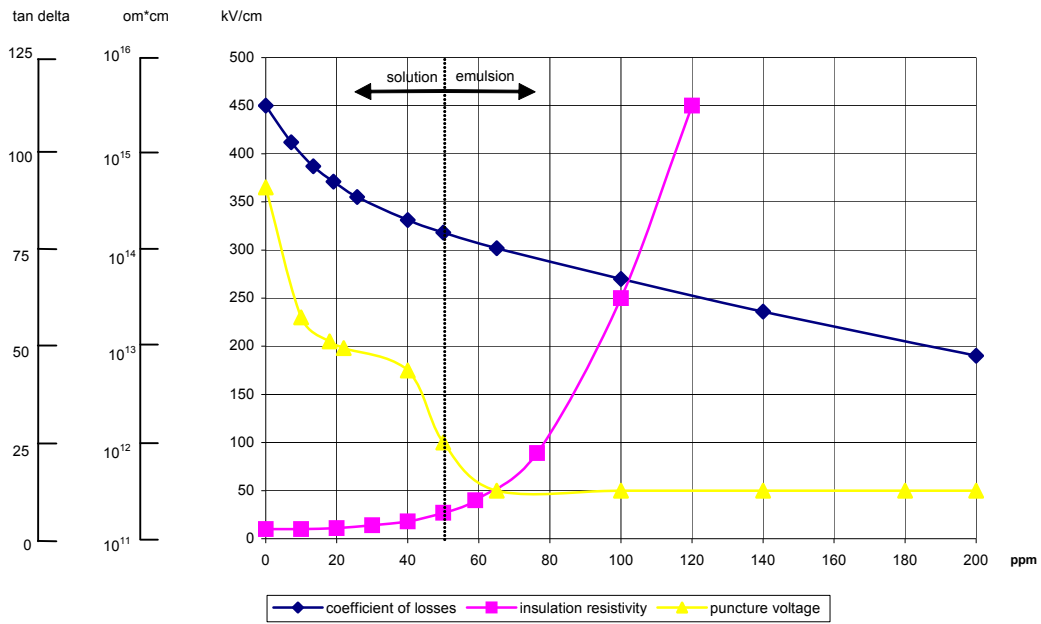

Schematic construction of the **S2000** Unit is presented in the following drawing:

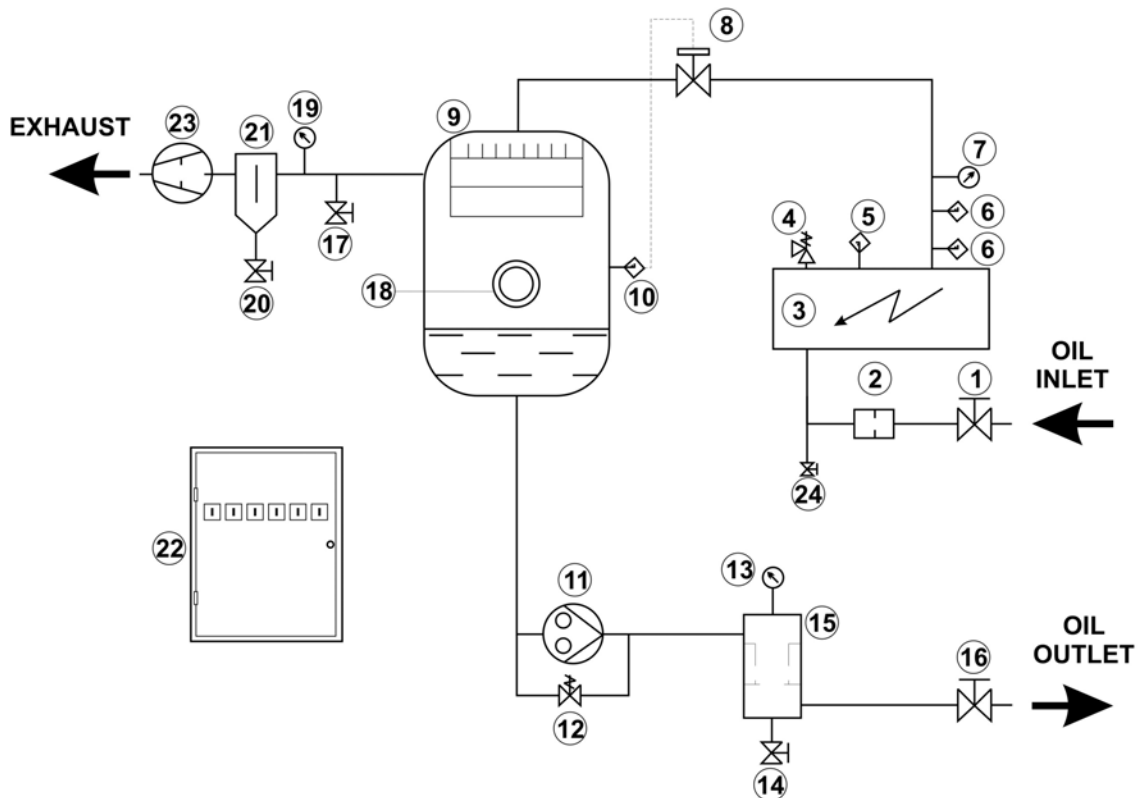

The details on the particular stages of operation are given with each part of the Unit in the following text.

THE UNIT CONSISTS OF:

- 1. Inlet valve** a spherical valve 1" with special "Teflon" gaskets

- 2. Coarse filter** as oil is often very polluted, the Unit is fitted with a large sized, easy to open and clean, coarse filter. Oil is conveyed at a reduced flow rate around a strong permanent magnet which retains steel particles and protects the gear pump from damages

- 3. Oil heater** 30 kW power of the heater is divided into two stages, each of 15 kW. Oil is heated indirectly by means of electric heating elements insulated from oil by pipes and air. The heating process is thereby gradually accomplished and, with the sufficiently large heating surface, any damage of oil is excluded. In addition, for each heating stage there is one 2.5 kW heater in each of the six heating pipes. Together with the thermal control (details of which are given in the following text) this allows heating of oil in individual stages, e.g. at higher temperatures quite "tenderly"

- 4. Safety valve** prevents increase of pressure in case oil is overheated

- 5. Safety thermostat** the Unit is equipped with a precise thermostat, acting as a safety thermostat. By means of other (control) thermostat, both heating stages can be controlled. This safety thermostat is designed to allow max. temperature of 90⁰C, with a construction that allows it both safety and control role.

- 6. Control thermostat** Is fitted onto the same housing with safety thermostat. It has an external button for the temperature range from 0⁰C up to 90⁰C; the button maximum position is 90⁰C, thus these control thermostat act as another safety device to prevent oil overheating. Both heating stages are adjusted with this thermostat. The swithching on of the second heating stage is delayed via time-relay (that can be adjusted) in order to avoid sudden electric overload. Control thermostat should be adjusted to cca. 60-65 ⁰C which represents an optimal temperature for oil processing
- 7. Thermometer** measures the temperature at the outlet of the oil heater
- 8. Electromagnetic valve** a special magnetic valve capable of operating in vacuum, resistant to transformer oil and high temperatures. It controls the oil level in degassing tank
- 9. Degassing tank** of a welded construction, with specially shaped separating sheets for equal distribution of oil. Oil is conveyed over the "RASIG" rings, where oil surface is significantly increased and gas fractions can be efficiently separated. In addition, the resting time of oil is increased to the maximum. The degassing tank is equipped with a sight-glass for the visual control of the process, as well as with a special lamp for illumination if the tank interior. The power supply of the lamp is 12 V for safety reasons
- 10. Floater** this floater, as essential control equipment, is procured from well-known European manufacturer. It protects the degassing tank from overfilling and, together with electromagnetic valve, prevents the insulating oil to penetrate into the vacuum pump

- 11. Gear pump** with maximum of 2000 l/h capacity. The capacity of the oil flow can be adjusted via frequency regulator installed at the control panel. Adjustable capacity is from 600 – 2000 l/h. This pump is specially designed to operate under vacuum conditions
- 12. Overflow valve** protects the Unit from an excessive rise of pressure in case outlet valve is negligently closed or because of some other reason
- 13. Manometer** for reading of fine filter dirtiness, through oil pressure rise. Filter should be cleaned when the pressure rises up to 2.5 bar
- 14. Valve** a spherical, closing valve for insulating oil sampling
- 15. Fine filter container** the fine filter container is of a size that allows it to accept a standard filter separating particles of 3 microns
- 16. Outlet valve** a spherical valve with special “Teflon” gaskets
- 17. Air valve** a spherical valve for aeration of the degassing tank in case of an excessive foaming of oil
- 18. Sight-glass for process control** equipped with search-light fitted on its left side to illuminate the interior of the degassing tank
- 19. Vacuum meter** measures vacuum in the degassing tank
- 20. Discharge valve** a spherical valve discharging condensate from the separator
- 21. Separator** of a special construction for separation of liquid fractions from gasses which are extracted out of degassing tank. It is equipped with sight-glass for control of separated water

-
- 22. Control panel** it consists of frequency converter, fuses, contactors, electric motors electrical protection, protection relays, transformer, main switch, internal wiring etc., for an automatic operation of the Unit. Control panel is equipped with total-stop taster for immediate shut down of the complete Unit in urgent situations. In addition on the front of control panel, there are three green indicator lights (L1, L2 and L3) for voltage presence. Beside this, above every cam switch, there is also an green light, that serves as an indicator of the current state (on / off) of the respective components. Control panel is equipped with the fan for cooling of its interior. The on/off temperature point for the fan can be adjusted via thermostat positioned in the control panel interior.
- 23. Vacuum pump** of 63 m³/h capacity, provides vacuum for operation of the Unit, equipped with a so-called "gas-ballast" valve. Maximal vacuum that could be achieved with this pump is 0.1 mbar
- 24. Drainage valve** a spherical valve for drainage of transformer oil from oil heater
- 25. Framework** a welded, sectional steel construction, which represents foundation for all described components of the Unit
- 26. Electric equipment** consisting of driving motors for the gear and vacuum pump and of internal wiring of the Unit. Suitable for three-phase, 50 Hz power supply. Unit is delivered with male 63A CEE connection installed at the control panel.

THE UNIT IS SUPPLIED WITH THE FOLLOWING ACCESSORIES:

- 27. Two flexible hoses** suction and discharge (1") hoses are specially designed, suitable for operation under vacuum and with oil. Equipped with cam lock adapters, each hose is 10 m long
- 28. Oil tub** oil retaining tub in case of oil leakage. It is placed under the complete Unit with a purpose of preventing environmental accidents and spillage of oil into the surroundings.
- 29. Rollers for base frame** rollers are installed for easier manipulation with the Unit. There are 4 swivelling rollers installed at the bottom of base frame.

INSTRUCTIONS FOR OPERATION

PREPARATION OF THE UNIT FOR OPERATION

1. Plug the Unit into the power supply source;
2. Connect oil hoses as short as possible;
3. Adjust the thermostats;
4. Close all valves;
5. Turn-on the main power switch;
6. Check the rotation direction by turning on of the pumps, several times in short intervals;
7. Turn-on the vacuum pump and open the “gas ballast” valve;
8. Turn-on the floater, which will automatically turn on the oil level control.

TURNING-ON OF THE UNIT (COMMENCEMENT OF FILTERING, DEGASSING AND DRYING PROCESS)

9. Close the “gas-ballast” valve on the vacuum pump;
10. When vacuum reaches 95 %, open the valve No. 1;
11. Open the valve No. 16 and turn-on the gear pump when oil level reaches the sight-glass level;
12. Adjust the oil flow with valve No. 1 and frequency converter;
13. When oil flow becomes constant, turn on the heaters;
14. If oil foams too much, lower the vacuum by easily opening of the valve No. 17.

UNIT SHUT DOWN

15. Turn-off the heaters. The gear pump shall continue operating for at least another 10 minutes;
16. Turn-off the gear pump;
17. Close the valve No. 1;
18. Leave the vacuum pump in operation for at least another 30 minutes with the “gas ballast” valve open;
19. Turn-off the main power switch;
20. Disconnect the power supply.

TROUBLESHOOTING

If malfunction occurs, the Unit should be checked in accordance with the following Table:

Problem	Cause of the problem	Remedy
1. Poor oil throughput (characteristic ringing sound coming from the gear pump indicating that there is not enough oil in degassing tank)	1.1. Dirty coarse filter	1.1. Clean the coarse filter
	1.2. The transformer is placed too low in relation to Unit	1.2. Place the Unit in a better position in relation to the transformer
	1.3. Pressure is too low and the pump operates in foam	1.3. Increase the pressure by adjusting valve No. 17
	1.4. The magnetic valve is closed	1.4. Open the magnetic valve
2. Oil level in the degassing tank is too high	2.1. The gear pump is not turned on	2.1. Turn-on the gear pump
	2.2. Pressure is too low	2.2. Increase the pressure by opening valve No. 7 easily
	2.3. Outlet valve is closed	2.3. Open the outlet valve
3. There is constantly too much foam in the degassing tank	3.1. Inlet oil contains water and air b) a rip in the feed hose or on some other joints c) flow back of oil to the transformer is not good	3.1. a) Repair or replace the hose, or repair the rip in the hose joint b) Ensure that the hose for oil flow-back is immersed in oil

Problem	Cause of the problem	Remedy
4. The vacuum pump is overfilled with oil	4.1. Evaporation in the degassing tank is too high	4.1. Drain the oil from the vacuum pump and refill the pump with new oil
	4.2. The condensate separator is over-filled	4.2 Empty the condensate separator (open the valve No. 20 and rise pressure in the degassing tank to reach atmospheric level)

SPECIAL NOTE:

Whenever the Unit is re-installed at the different location, the rotation direction of the gear and vacuum pump should be necessary checked. Check phase sequence by observing a GREEN and RED indication lamps at the control panel. (GREEN light should be ON). If the direction is opposite, the two phases in the electrical plug should be reversed (no phases reversion is allowed in the motors, as they are adjusted to the Unit).